

# POCKET DOOR MORTISE HOLE PREPARATION

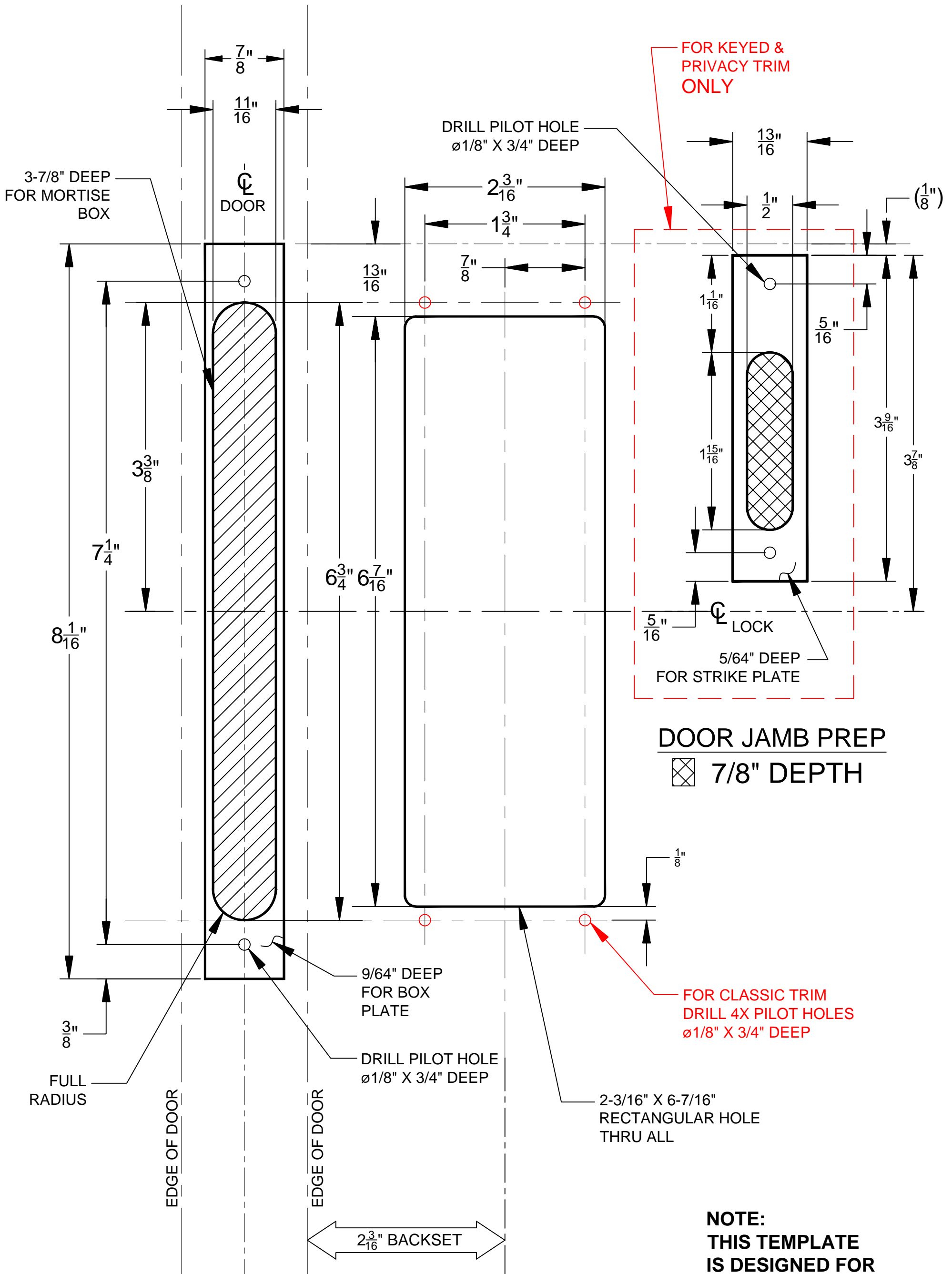

\* NOTE: 8-1/2" X 11" COPY OF THIS TEMPLATE NOT TO SCALE.

## 1 Install Lock Body

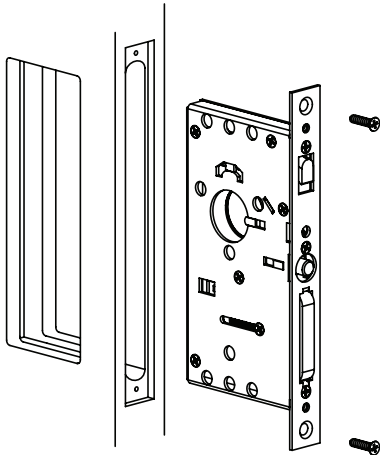

See template for door prep specifications

## 2 Install Drive Bar Cylinder

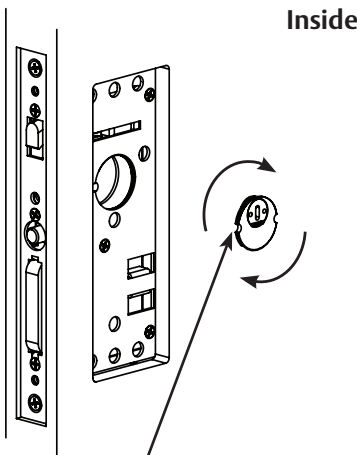

Note: Notch on cylinder must be in the 9 o'clock position when fully screwed into lock body.

## 3 Mount Inside Plate

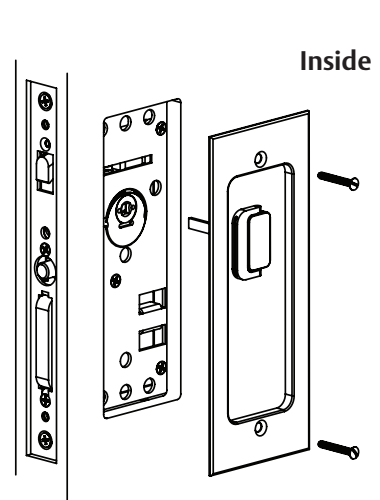

## 4 Mount Outside Plate and Thread Key Cylinder

Install Key Cylinder by threading it clockwise onto lock body plate

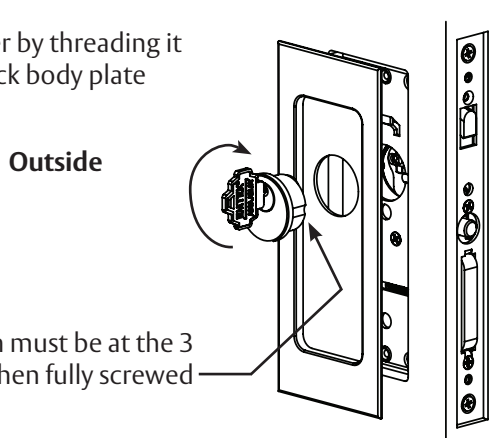

Key Cylinder notch must be at the 3 o'clock position when fully screwed in lock body.

## 5 Tighten Drive Bar Cylinder

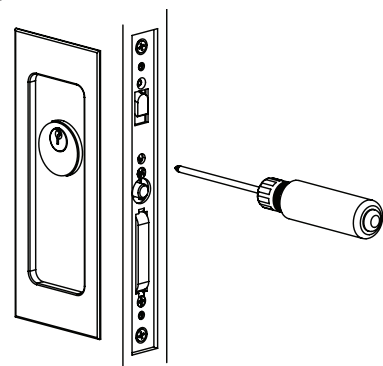

Tighten locking screw to engage notch on cylinder

## 6 Install Trim Plate

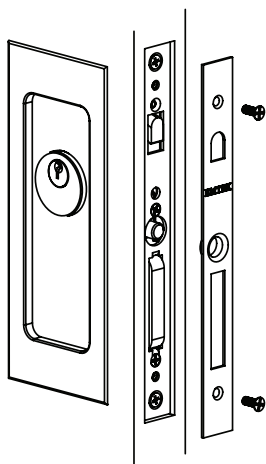

## 7 Install Door Jamb

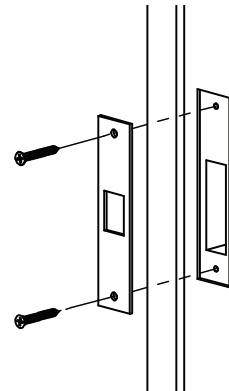

Drill two 7/64" pilot holes

See template for door jamb prep specifications